

Technical data sheet

Wall and support bracket AWG 15 A2

Item number: 6420631



Light-duty wall and support bracket with welded head plate for screwless mesh cable tray fastening.

Fastening of the bracket to the U support of width 400 mm or greater using a hexagonal bolt through both sides of the support. Please insert suitable spacers.



A2 Stainless steel

2B Bright, treated

Master data

Item number	6420631
Type	AWG 15 31 A2
Description 1	Wall and support bracket
Description 2	for mesh cable tray
Manufacturer	OBO
Dimension	B310mm
Material	Stainless steel
Surface	Bright, treated
Surface standard	
Smallest sales unit	1
Unit of quantity	Piece
Weight	33 kg
Weight unit	kg/100 pc.

Technical data sheet

Wall and support bracket AWG 15 A2

Item number: 6420631



Dimensions

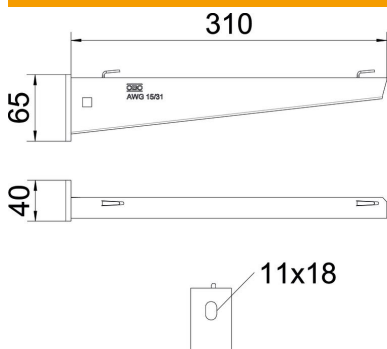

Length	40 mm
Width	310 mm
Height	65 mm
Dimension A	40 mm
Dimension B	310 mm
Dimension H	65 mm
Dimension L	310 mm

Technical data

Version for	Wall and support bracket
F in kN	1.5 kN
Maintain electrical functions for width max.	no
for width min.	300 mm
Hole diameter	300
Rustproof steel, pickled	11 mm
Angle range, max.	yes
Angle range, min.	90 mm

Loads

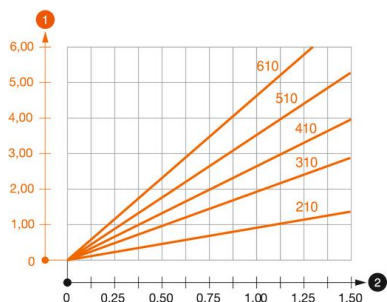

Load diagram, bracket type AW G 15

- 1 Bending of the bracket tip at permitted bracket load
- 2 Permitted bracket load in kN without man load
- Load curve with bracket lengths in mm

Characteristic anchor load values for wall and support bracket AW G 15

Wall fastening	Max. load [kN]							
	Bracket width [mm]							
Anchor type	110	160	210	310	410	510	560	610
BZ3 10x90/0-30	1.5	1.5	1.5	1.47	1.25	1.13	0.95	0.94

Die angegebenen Werte basieren auf ungerissenen Beton der Festigkeitsklasse C20/25. Die Einbaubedingungen der ETA-Zulassung (Dübel) sind zu beachten!